



HELIXX™ Poly Hopper Spreader

#11780, 11790, 11800, 11810

1.5, 2.25, 3.5, & 5.0 yd³

Parts List

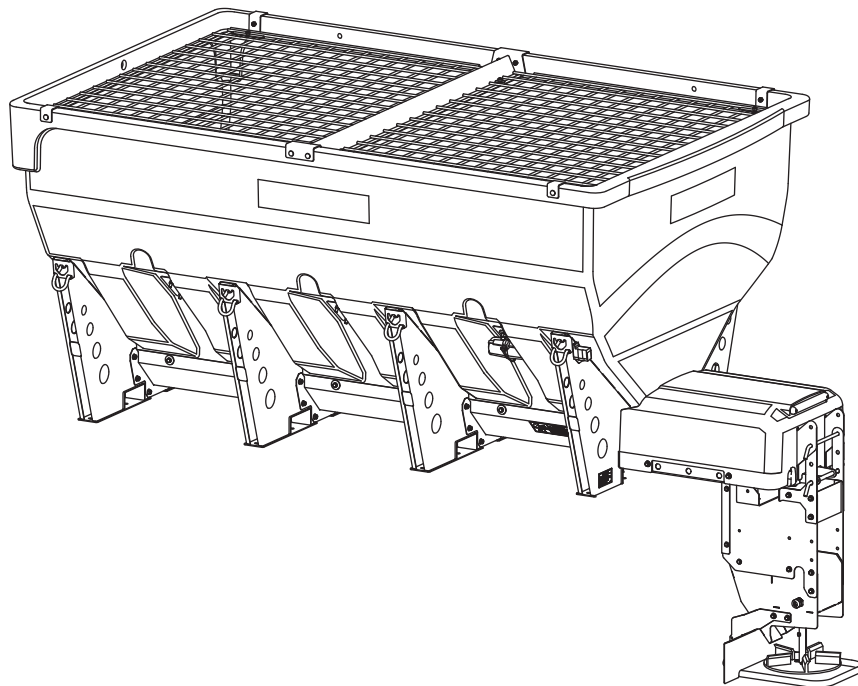

This Parts List is for SnowEx® HELIXX poly hopper spreaders with serial numbers beginning with 190101 and higher.

HELIXX™ POLY HOPPER SPREADERS

HOPPER ASSEMBLY

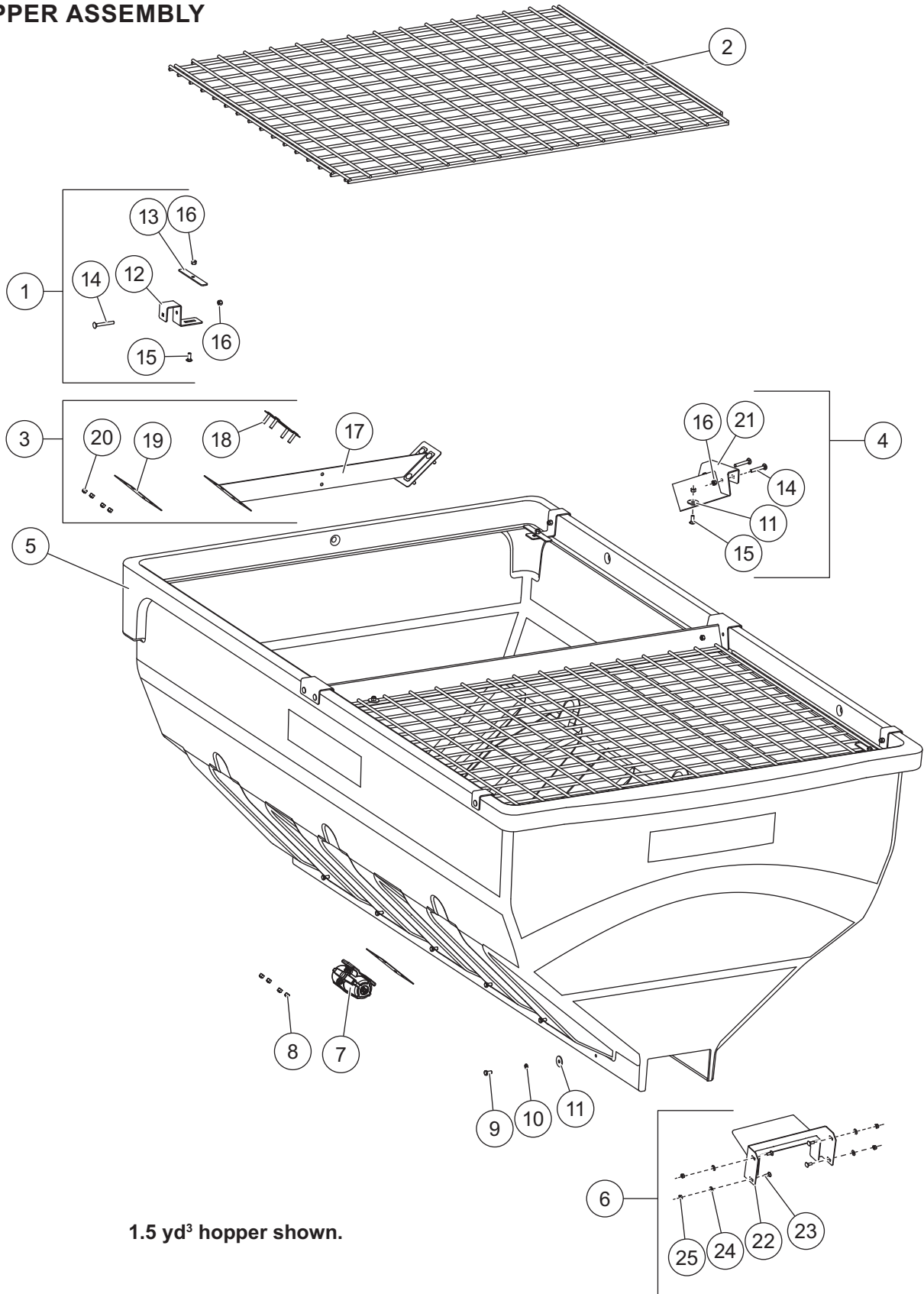

HELIXX™ POLY HOPPER SPREADERS

DRIVETRAIN ASSEMBLY

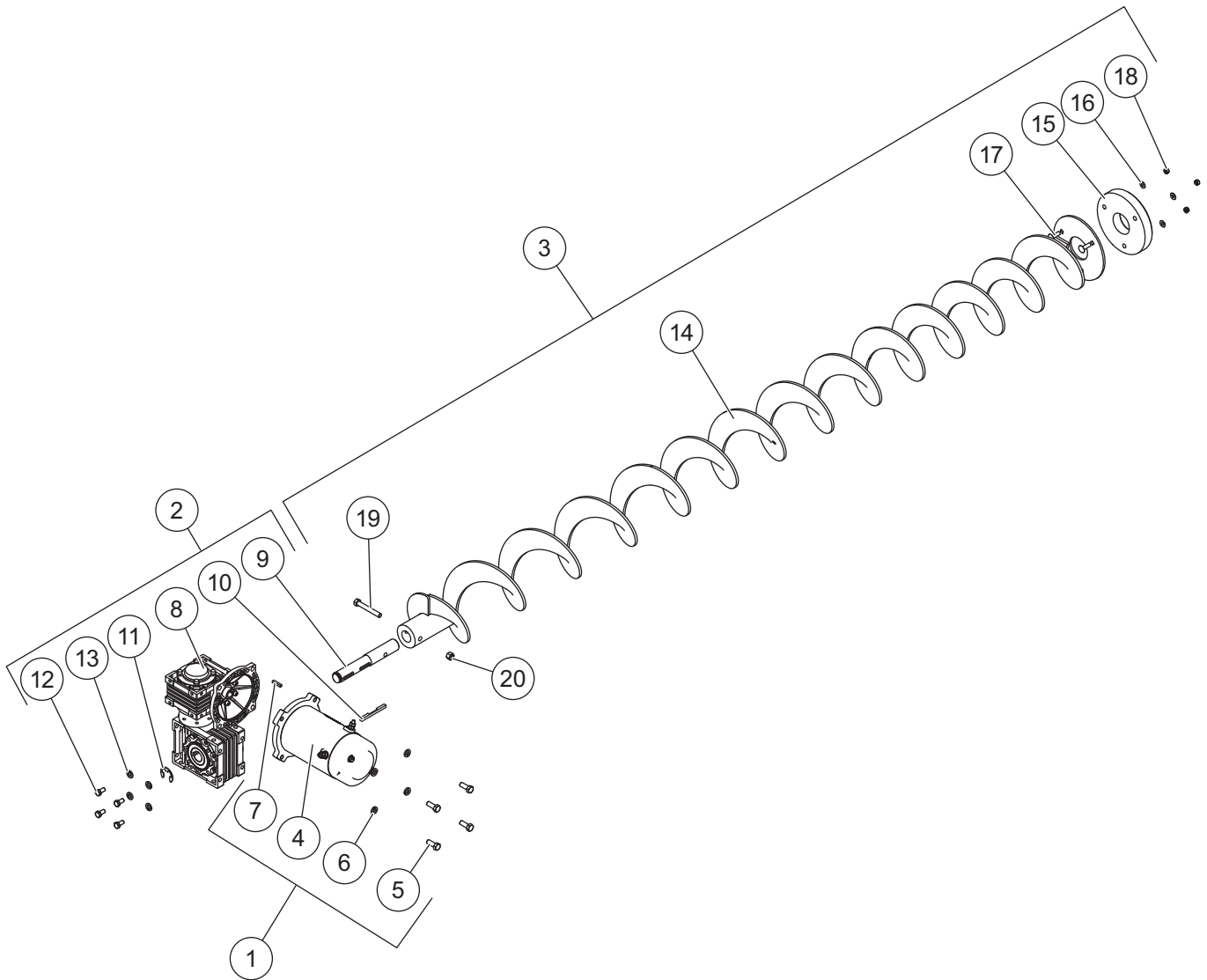

HELIXX™ POLY HOPPER SPREADERS

Drivetrain Assembly Components							
Item	Part	Qty	Description	Item	Part	Qty	Description
1	85432	1	Motor Kit, 3/4 hp	3	85424	1	Service Kit Auger, Long
ns	85479	1	Motor Kit, 1/2 hp	ns	85423	1	Service Kit Auger, Short
2	85431	1	Service Kit Transmission				
Item 1				85432 Motor Kit, 3/4 hp			
4	D6872	1	Motor, 3/4 hp 1750 rpm	6		4	3/8 Spring Lock Washer
5		4	3/8-16 x 1 Hex Cap Screw	7	65195	1	Machine Key, 3/16 x 1
				85479 Motor Kit, 1/2 hp			
ns	D6825-1	1	Motor, 1/2 hp 1750 rpm	6		4	3/8 Spring Lock Washer
5		4	3/8-16 x 1 Hex Cap Screw	7	65195	1	Machine Key, 3/16 x 1
Item 2				85431 Service Kit Transmission			
8	99067	1	10 x 10 x 2 Worm Gear	11		1	1" Retaining Ring
9	11892	1	Auger Drive Shaft	12		4	M8-1.25 x 16 Hex Cap Screw SS
10	99572	1	Machine Key, 1/4 x 3	13		4	M8 Spring Lock Washer SS
Item 3				85424 Service Kit Auger, Long			
14	11860	1	Auger, 112"	18		3	5/16-18 Hex Locknut GB SS
15	11888	1	Auger Front Bearing	19		1	3/8-16 x 2-3/4 Hex Cap Screw SS
16		3	5/16 Flat Washer SS	20		1	3/8-16 Hex Locknut GB SS
17		3	5/16-18 x 1 Carriage Bolt				
				85423 Service Kit Auger, Short			
ns	11850	1	Auger, 82"	18		3	5/16-18 Hex Locknut GB SS
15	11888	1	Auger Front Bearing	19		1	3/8-16 x 2-3/4 Hex Cap Screw SS
16		3	5/16 Flat Washer SS	20		1	3/8-16 Hex Locknut GB SS
17		3	5/16-18 x 1 Carriage Bolt				
ns = not shown		G = Grade		SS = Stainless Steel		M = Metric	

HELIXX™ POLY HOPPER SPREADERS

TROUGH ASSEMBLY

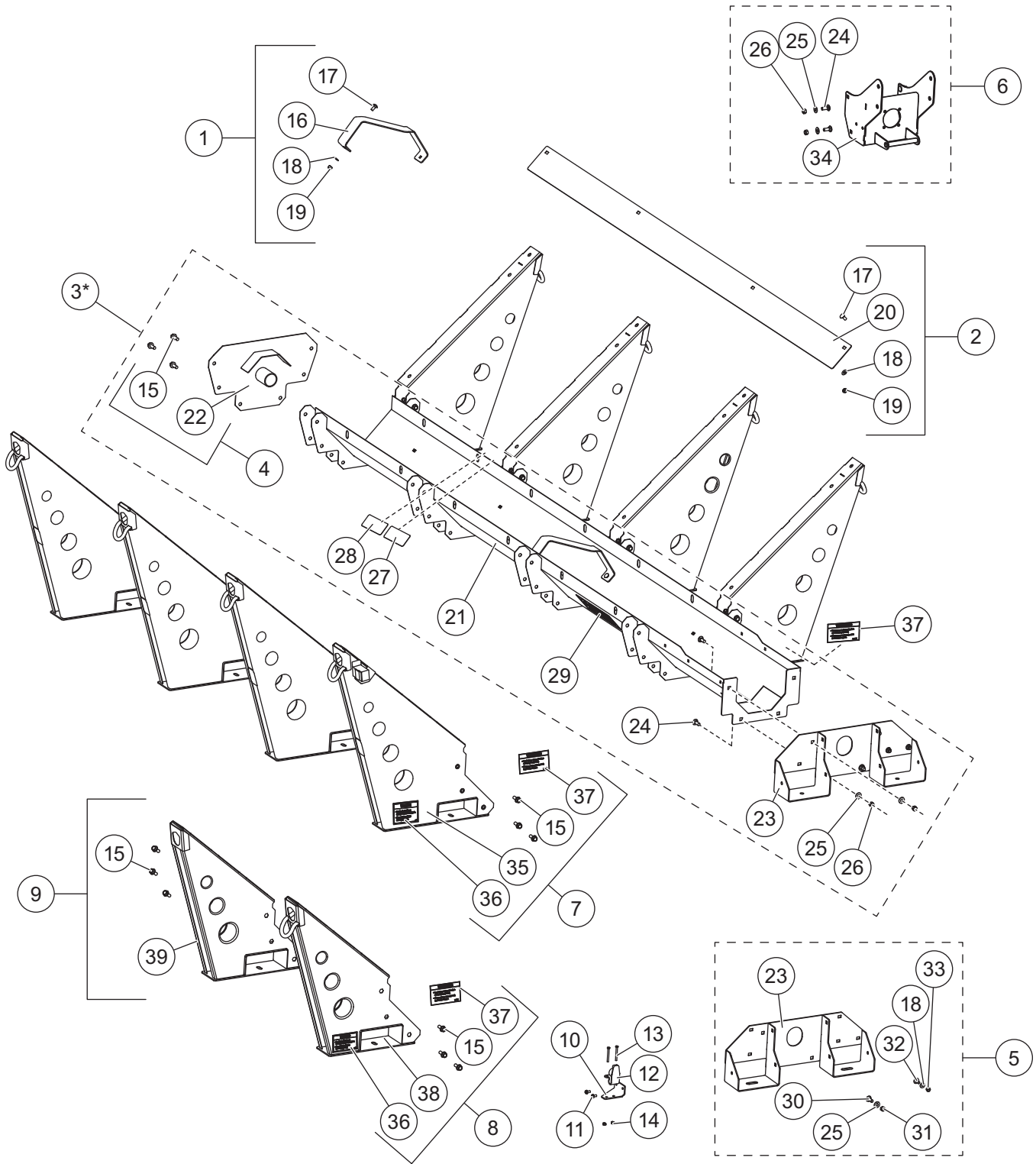

* Hopper legs not included in trough service kit (item 3).

HELIXX™ POLY HOPPER SPREADERS

ELECTRICAL BOX ASSEMBLY

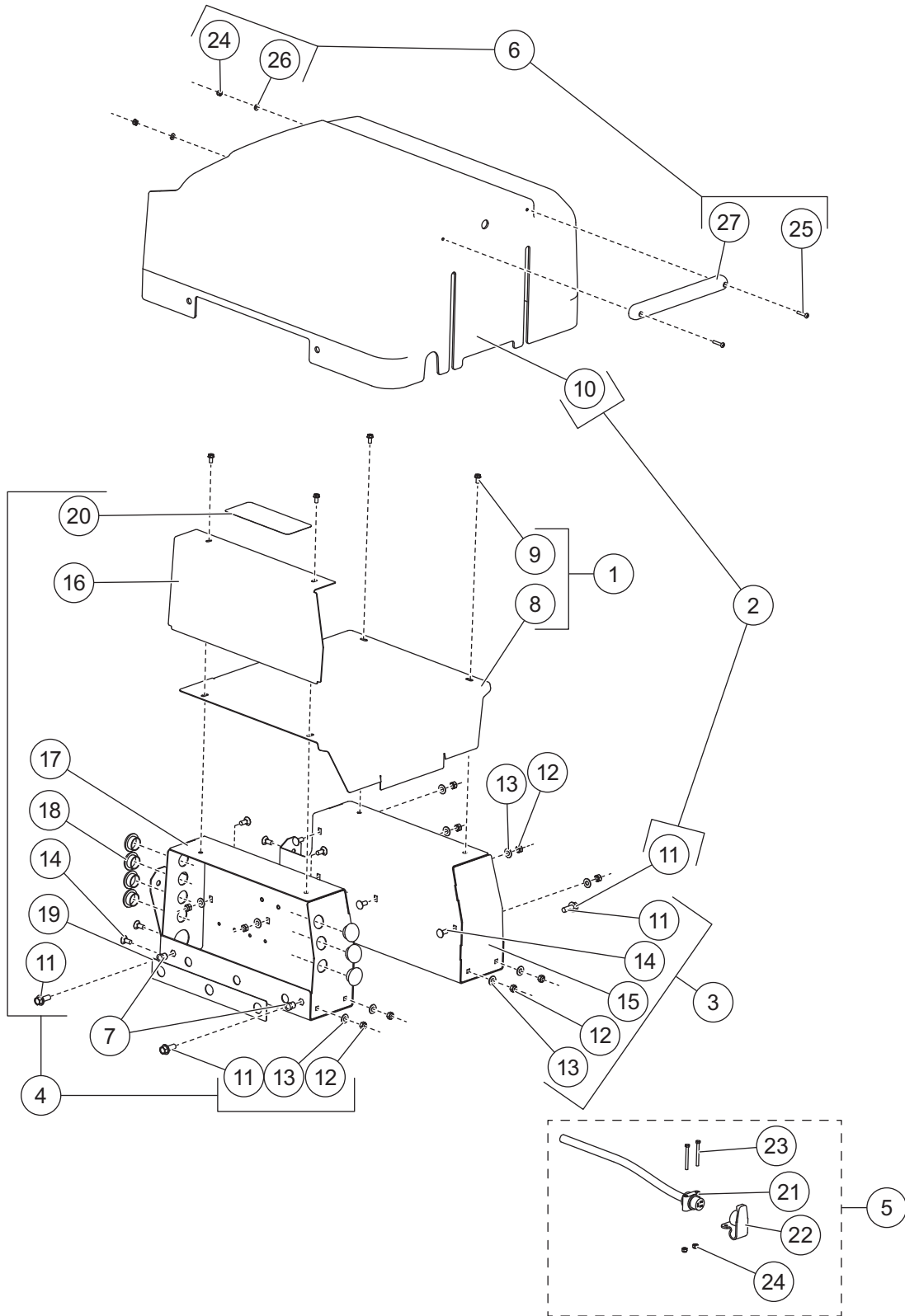

HELIXX™ POLY HOPPER SPREADERS

SPINNER DRIVE ASSEMBLY

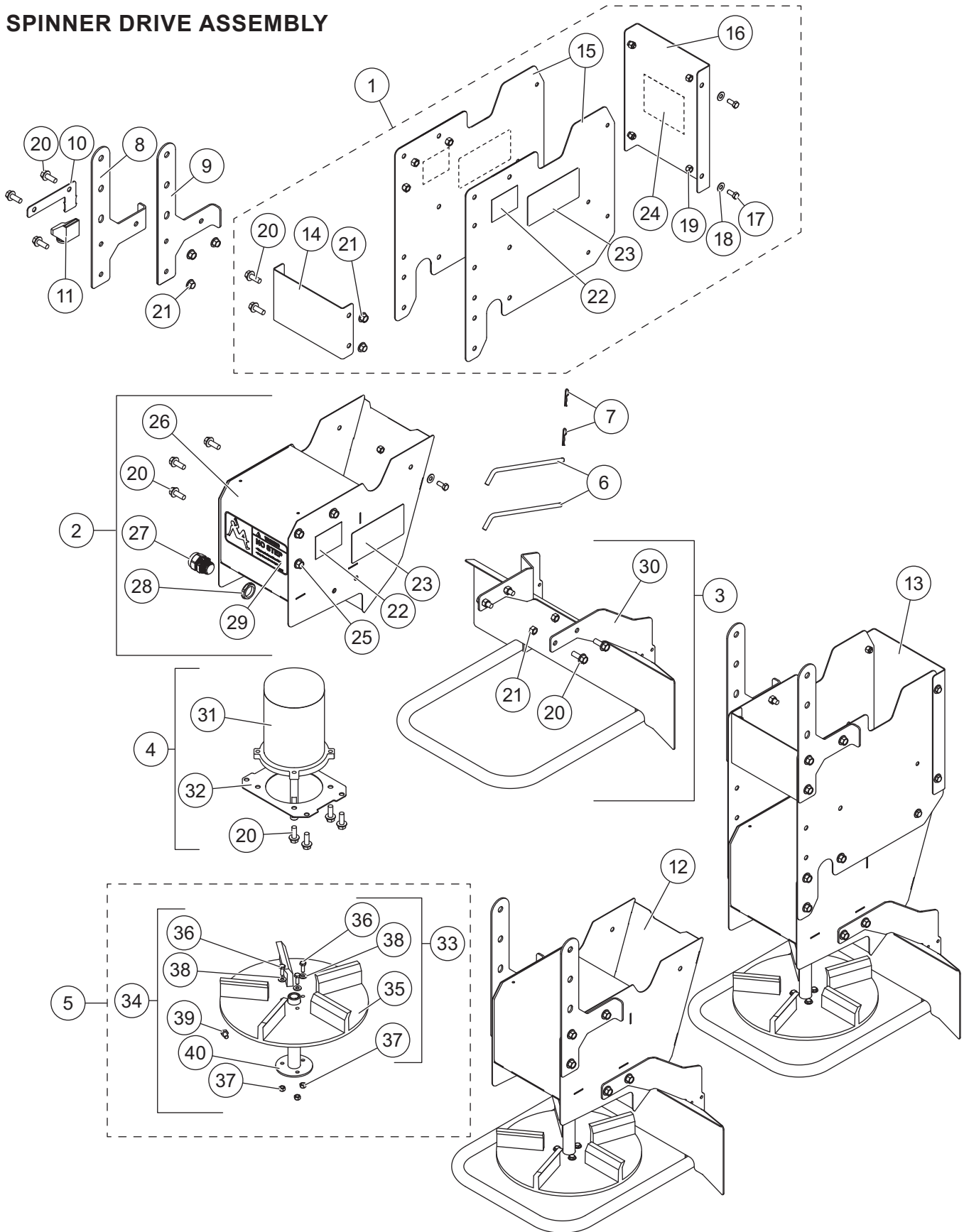

HELIXX™ POLY HOPPER SPREADERS

Spinner Drive Assembly Components						
Item	Part	Qty	Description	Item	Part	Qty Description
1	80221*	1	Chute Extension Kit	8	11871	1 Chute Hanger – DS
2	85434	1	Spinner Drive Housing	9	11872	1 Chute Hanger – PS
3	85437	1	Spinner Guard Service Kit	10	90774	1 Cable Boot Bracket
4	85436	1	Spinner Motor Service Kit	11	11992	1 Spinner Harness Dust Cover
5	80222	1	Spinner Disk Kit	12	77570	1 Spinner Drive Assembly Kit
6	11981	2	Chute Locking Pin	13	77571	1 Spinner Drive Extension Assembly Kit
7	D4135	2	0.093 x 2-3/8 Hairpin Cotter, Zinc			
Item 1 80221* Chute Extension Kit						
14		1	Chute Extension Stiffener	20		6 3/8-16 x 1 Serrated Flange Hex Cap Screw SS
15		2	Chute Extension Side Plate			
16		1	Chute Extension Funnel	21		6 3/8-16 Locknut SS
17		6	5/16-18 x 3/4 Hex Cap Screw SS	22	29593	2 Label – Warning, Multiple Pinch Points
18		6	5/16 Flat Washer SS	23	11100	1 Label – Warning, Rear Camera
19		6	5/16-18 Hex Locknut SS	24	92971	1 Label – Warning, Disconnect
				ns	92969	1 Label – Warning, Chute Disconnect
Item 2 85434 Spinner Drive Housing						
20		6	3/8-16 x 1 Serrated Flange Hex Cap Screw SS	26		1 Chute Motor Enclosure
				27		1 10/2 3/4 NPT Strain Relief
22	29593	2	Label – Warning, Multiple Pinch Points	28		1 3/4 Locknut, Nylon
23	11100	1	Label – Warning, Rear Camera	29	D6545	1 Label – Warning, No Step
25		6	3/8-16 Hex Rivnut SS			
Item 3 85437 Spinner Guard Service Kit						
20		4	3/8-16 x 1 Serrated Flange Hex Cap Screw SS	21		4 3/8-16 Locknut SS
				30		1 Deflector
Item 4 85436 Spinner Motor Service Kit						
20		4	3/8-16 x 1 Serrated Flange Hex Cap Screw SS	31	D6887	1 Spinner Motor, Direct Drive
				32		1 Spinner Motor Plate
Item 5 80222 Spinner Disk Kit						
33	85438	1	Spinner Disk Service Kit	34	85439	1 Spinner Disk Mount Service Kit
Item 33 85438 Spinner Disk Service Kit						
35	D6823	1	12 x 5/8 Spinner	37		3 1/4-20 Locknut
36		3	1/4-20 x 1 Serrated Hex Washer-Head Cap Screw SS	38		3 1/4 Flat Washer SS
Item 34 85439 Spinner Disk Mount Service Kit						
36		3	1/4-20 x 1 Serrated Hex Washer-Head Cap Screw SS	38		3 1/4 Flat Washer SS
				39		1 5/16-18 x 1/2 Hex Cap Screw SS
37		3	1/4-20 Locknut	40	11874	1 Spinner Hub

SS = Stainless Steel

* Accessory only for 1.5 & 2.25 yd³ hopper spreaders.

HELIXX™ POLY HOPPER SPREADERS

CONTROL & ELECTRICAL COMPONENTS

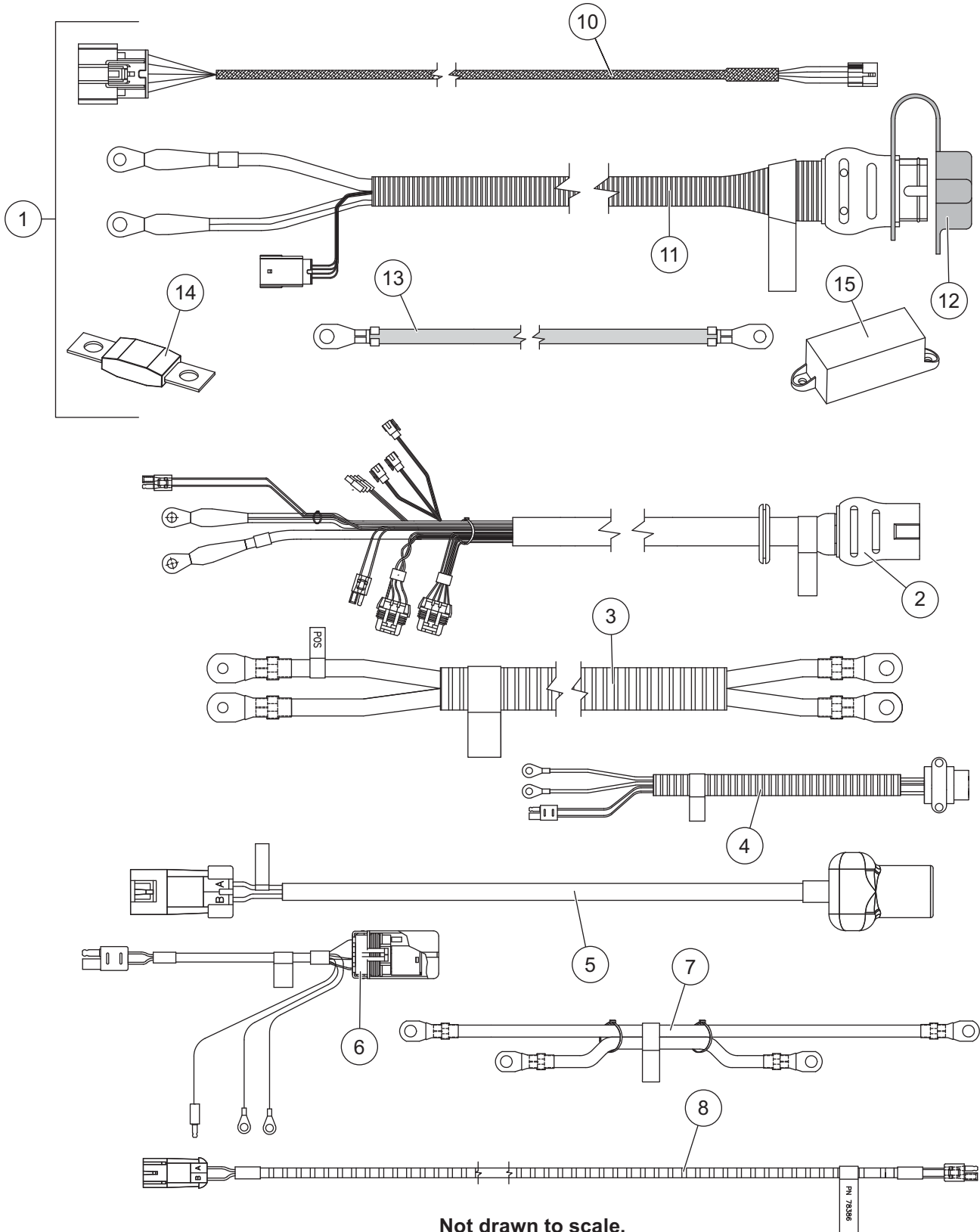

Not drawn to scale.

HELIXX™ POLY HOPPER SPREADERS

CONTROL & ELECTRICAL COMPONENTS

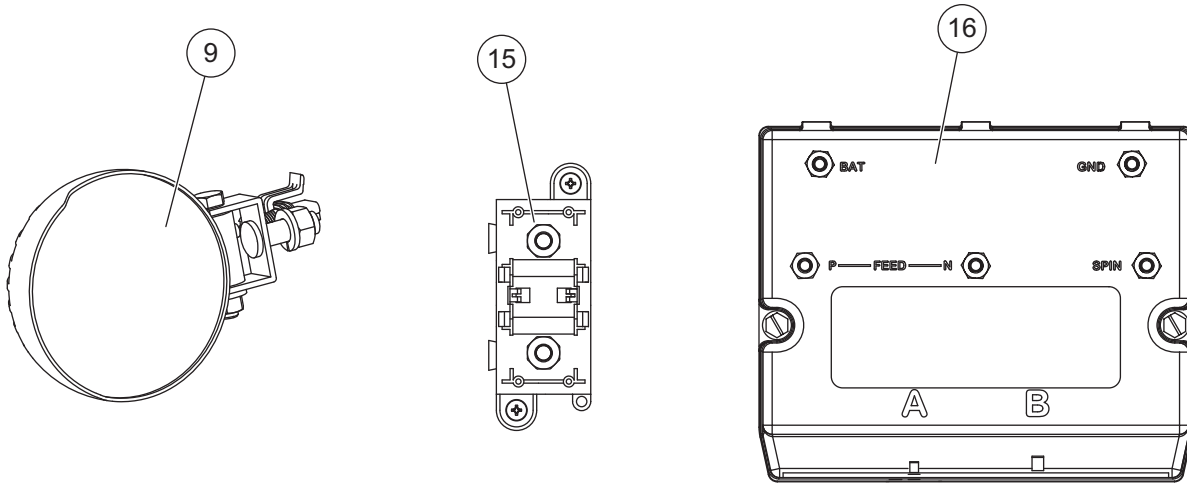

Cables & Harnessing / Electrical Enclosure Assembly							
Item	Part	Qty	Description	Item	Part	Qty	Description
1	83695	1	Vehicle-Side Harness Kit	9	78377	1	LED Work Light
2	83688	1	Hopper Cable Assembly	ns	83712	1	Extension Harness – 24"
3	83704	1	Module to Auger Motor Cable Assy	ns	D6514	1	Center High Mount Stop Light (CHMSL)
4	85448	1	Spinner Module Cable Assembly	ns	*	2	#10-32 x 1-1/4 Machine Screw SS
5	85435	1	Spinner Motor Cable Assembly	ns	*	2	#10-32 Locknut SS
6	78382	1	Vibrator Harness Assembly	ns	78391	1	Vibrator Extension Harness, 94"
7	78385	1	Module to Isolated Stud Cable Assy	ns	74044	1	Auxilliary Work Light Kit
8	78386	1	Harness Assembly – 72"				
Item 1 83695 Vehicle-Side Harness Kit							
10	69902	1	Vehicle Control Harness	14	95836	1	Fuse, 100A
11	83690	1	Vehicle Harness Assy (incl. item 12)	15	95837	2	Fuse Holder/Isolated Stud Block
12	99759	1	Plug Cover	ns		6	Cable Tie, HD
13	22511	1	22" Battery Cable – Red	ns		10	Cable Tie, 15.35"
74044 Auxilliary Work Light Kit							
8	78386	1	Harness Assembly – 72"	9	78377	1	LED Work Light
Electrical Box Components							
15	95837	1	Fuse Holder/Isolated Stud Block	16	52375	1	Spreader Module, 5-Post
ns = not shown				SS = Stainless Steel			

* CHMSL mounting hardware.

HELIXX™ POLY HOPPER SPREADERS

CONTROL & ELECTRICAL COMPONENTS

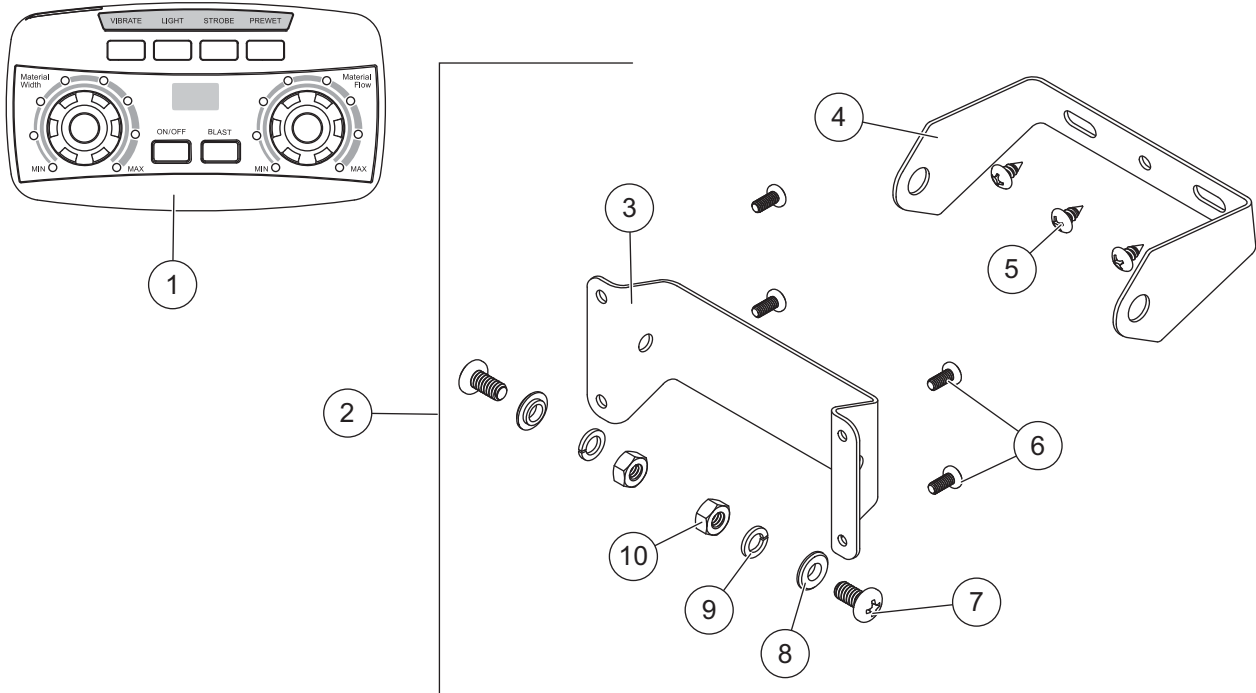

52430 Cab Control Kit							
Item	Part	Qty	Description	Item	Part	Qty	Description
1	52432	1	Cab Control 2-Knob	2	52345	1	Cab Control Bracket Kit
Item 2			52345 Cab Control Bracket Kit				
3		1	Bracket, Control Inner	7		2	1/4-20 x 1/2 Pan Head Machine Screw SS – Black
4		1	Bracket, Control Outer	8		2	1/4 Shoulder Washer SS – Black
5		3	#10 x 3/8 Pan Head Tapping Screw SS	9		2	1/4 Spring Lock Washer SS
6		4	#8 x 3/8 Pan Head Machine Screw	10		2	1/4-20 Hex Nut G5 – Black
			SS = Stainless Steel				G = Grade

HELIXX™ POLY HOPPER SPREADERS

ACCESSORIES

Part	Description	Part	Description
68790	Ratchet Strap Kit	11796	Bungee Kit, 1.5 yd ³
74044	Auxiliary Work Light Kit	11797	Bungee Kit, 2.25 yd ³
83745-1	Strobe Light Kit	11798	Bungee Kit, 3.5 yd ³
78402	Vehicle-Side Harness Kit	11799	Bungee Kit, 5.0 yd ³
83724	Vibrator Kit DC-100, Poly Case	11961	Inverted V Kit (1.5 & 2.25 yd ³ hoppers)
83734	Vibrator Kit DC-200	11963	Inverted V Kit (3.5 & 5 yd ³ hoppers)
99690	Tie-Down Kit, SH Chain		

Liquid Kits					
Part	Description	Qty			
		1.5 yd ³	2.25 yd ³	3.5 yd ³	5.0 yd ³
74610	100 gal HELIXX Liquid Kit, 4 x 25-gal Tanks	1	1	–	–
74620	200 gal HELIXX Liquid Kit, 4 x 50-gal Tanks	–	–	1	1
74630	100 gal HELIXX Liquid Kit, 2 x 50-gal Tanks	–	–	1	1



TrynEx International, LLC
531 Ajax Drive
Madison Heights, MI 48071-2429
www.snowexproducts.com

 A DIVISION OF DOUGLAS DYNAMICS, LLC

Copyright © 2021 Douglas Dynamics, LLC. All rights reserved. This material may not be reproduced or copied, in whole or in part, in any printed, mechanical, electronic, film, or other distribution and storage media, without the written consent of TrynEx International, LLC. Authorization to photocopy items for internal or personal use by TrynEx International outlets or spreader owner is granted.

TrynEx International reserves the right under its product improvement policy to change construction or design details and furnish equipment when so altered without reference to illustrations or specifications used. TrynEx International or the vehicle manufacturer may require or recommend optional equipment for spreaders. Do not exceed vehicle ratings with a spreader. TrynEx International offers a limited warranty for all spreaders and accessories. See separately printed page for this important information. The following are registered (®) or unregistered (™) trademarks of Douglas Dynamics, LLC: HELIXX™, SnowEx®.

Printed in U.S.A.